

Development of an artificial LED lighting system for indoor farming

Desarrollo de un sistema de iluminación artificial LED para cultivos en interiores-Vertical Farming (VF)

Received: 29- 12 - 2015 Accepted: 22-11-2016

Yesid Ramos Gonzalías¹
Eduardo Ramírez Lasso²

¹ Colombian, Electronics and Telecommunications Engineer, Universidad Autónoma de Occidente – Cali. jesid.ramos@gmail.com.

² Colombian, Mechanics Engineer, Manager of Engineering and Design Line Tecnoparque Astin – Cali. e.ramirezlasso@gmail.com.

Abstract

The concept of vertical farming, also related to Building Integrated Agriculture (BIA), is a new approach to production based on the idea of locating high performance crops system in buildings to produce food inside them, using renewable resources, local energy, and water. Lighting systems used in indoor farming are known as growth lights and they are used as an artificial light sources. These operate in three different ways: 1) they provide all the light that the plant needs for growing; 2) they complement the natural light, especially in winter, where daylight hours are shorter than in other seasons 3) increase the period of daylight in order to activate the growth and flowering. This reading describes the most important characteristics of LED (Light Emitting Diode) lighting systems for indoor farming and a prototype lighting that emulates solar performance, that is, the intensity of light varies in a defined time period (6 hour light phase and 2 hours dark phase make a work cycle, which is repeated three times a day), where the operating model will be to provide all the light that the plant needs for healthy growth, in an environment free from sunlight.

Keywords: light; led lighting; wavelength; interior crops; vertical farming.

Introduction

The last decade of the XX century and early XXI century, have become an epoch of intense studies about the effects of the photosynthesis upon agricultural with partial or complete artificial light sources (Heinrich Böll Stiftung, 2009; Specht et al., 2014; Winter Green Research, 2014). The food selection and production time (for example, vegetables and fruits) can be artificially controlled through the environment. Some of the most important variables that act there, are the light intensity,

temperature and farm humidity. Studies held by (Caplow & Nelkin, 2007; Ahmad, Nurul, Robiah & Nurul, 2013; Tongxin et al., 2012), have been based in various phenomena, such as the declared spectrum influence and the light irradiation intensity in the plant's mass growth or the wavelength (λ) performance. Such artificial irradiation process, was difficult to perform before. Inefficient and expensive tries were driven with the use of tungsten and after that through fluorescent lamps fed by alternate current. Currently the LED devices technology has quickly advance in different applied sciences fields since they allow the production of bright light and long duration. For the indoor crops, the only cast the corresponding wavelengths to own values and close to absorption peaks of typical photo-chemical of a plant which is between 400 and 500 nanometers (nm) and 600 and 700 nm, the wavelengths that stimulate seeding, vegetable growth, development and plant blooming through their photo-sensitive stains (Winter Green Research, 2014). In comparison to other growth lights, these devices for indoors farming are attractive since

they don't require ballasts and cast way less heat than any other lightning system.

Difficulties

The growing urbanization and the world's construction boom has drawn the importance for the environmental efficiency in the built environment, that is to say, in the cities. For the 2050, is estimated that 80% of the population will live in urban zones (nowadays 60% of the population does). For this date, the population will raise to an approximate of 9.2 billion people, and most of them in developing countries. Many experts sustain that unless tough measures are taken, the world could face a dramatic lack of food in the farmable land. Heinrich, (2009). Starvation and ecological catastrophes are some of the most possible serious consequences due to the already known flooding, crop poisoning, ground frosting and forest fires as can be observed on Figure 1.



Figure 1. Catastrophic climatic consequences. Source: The theory behind the concept of vertical farming . South Carolina. Recovered from http://media.clemson.edu/public/restoration/iae/vfarm/student_verticalfarming.pdf

During the last ten years, diverse electromagnetic stimulation ways and sources for the optimal development for the photosynthesis process for plants in natural and artificial manners have been implemented. The main free source capable of doing it, is the sun, since it casts X rays, ultraviolet light, visible light, infrared light and even radio waves, however inside of these great variety of electromagnetic waves that the sun casts, some types are not appropriate for every living being, and specially for some plants, for

example the B and C ultraviolet light; besides, the sun light is present technically for 12 hours, according to the weather station and the place where it is; these hours may vary positively or negatively for the process in concern, compromising the productive capacity of the plants.

On other hand are the artificial sources such as: Metal halide lamps, incandescent lamps, mercury dust lamps and high pressure sodium lamps (HPS). Although are

highly used to accelerate the photosynthesis process and thus the plant development in vertical farms, places and times where darkness prevails more than luminosity, they possess big difficulties such as: size, movable components, dangerous gases compounds for humans, high energetic consume, low life span, among others, and the great variety of negative characteristics, these last post a thread against the continuation of some of them.

Currently most of the used energy is wasted in the heat production, only between the 10 – 30 % of the energy is converted into photosynthetically active radiation (PAR), which the plant can use for photosynthesis.

Artificial LED illumination

In essence for this argument, the need to propose and test an illumination system capable of positively stimulating the photosynthesis process in some plants, in an efficient way for the indoors farming where the total and/or partial control and automatized processes or works can reveal the importance of the artificial led illumination. Thus, the artificial illumination for the plant growing can work in three different ways:

- Providing light all the necessary light for the plant to grow.
- Complementing natural light, mainly in winter months, where the light days are short.
- Increase the light period with the goal to increase growing and blooming.

The LED illumination has taken much more force than any other applied artificial light technology to stimulate plant growth. Due to the fact that they are elements in solid state which means that they don't possess movable parts such as filaments that can wear down due to vibrations, and also the low almost inexistent light radiation in forms of light, the devices can be placed very close to the plants and can be configured to cast a high light flux to the plants and even with high intensities, (Tennessee, Singaas & Sharkey, 1994; Barta, Tibbits, Bula & Morrow, 1992) don't generate ultraviolet nor infrared light, which represents a relief for who has to be exposed in the inside of a farm for hours. The average life time is around 50.000 hours and its turning on time is practically instantaneous, its simplicity makes it easy to contain several LED types in a single encapsulation, its cost decreases each day and its efficiency increases,

which indicates that the energetic consumption is lower than any other artificial light.

Another important aspect of the LED lamps and/or devices is that the light casting degree is lesser to 180 degrees, which implies that every generated light will be focused towards the frontal part of the device, something that doesn't happen with other illumination systems, which generate light in all directions, making necessary the use of surfaces that reflect the cast light and focus ahead, making losses due to reflection (Macías; Ramos & Ulianov 2012).

So, one of the most relevant functions of the LED is to cast light in a specific wavelength in order to stimulate the plant growth. Thanks to the low electric energy consumption that these devices possess, they are capable of being integrated to modern alternative energy systems for their operation, as in solar and Eolic systems. As they can also be easily integrated in digital control systems, making easier complex illumination programs such as the intensity variation or spectral composition over the course of the plant development stages (Yeh & Chung 2009).

Hence, although the LED devices have a great number of advantages, their main disadvantage is in their high acquisition and final implementation cost for their correct operation and time prolongation, wince for their correct operation and time prolongation, is necessary to develop electronic circuits capable of controlling important variables such as current and tension of such. Thus, the challenge being to find the relation of correct wavelengths, the most appropriate solar emulation and perfection the application strategies that meaningfully reduce the costs related with energy, keeping and increasing the production quality, and reducing the negative environmental impacts in the production of food.

Relation between light and plant growth

The plants require light throughout all of their life span, since the seeding until the blooming and the fruit and/or seed production. Thus, the light is an electromagnetic wave that travels through time and space as packages of discrete energy, called photons. This can be measured in many forms, each photon has a specific wavelength and an energy level as described next. Such variables describing light are: *Foot-candles*, *lux*, *watts*, $\mu\text{mol}/\text{m}^2/\text{s}$ and $\text{mol}/\text{m}^2/\text{day}$.

$$E = (h * c) / \lambda \quad (1)$$

E= Energy of each photon expressed in J (Joule).

h = Planck's constant: $6,63 \times 10^{-34}$ J.s

c = Light speed: $3,0 \times 10^8$ m/s

λ = Wavelength, expressed in meters.

By this, the provided energy by each photon in a particular artificial LED illumination system to plants is of:

Wavelength–Blue Color 458: $434,279 \times 10^{-21}$ J

Wavelength–Red Color 656: $303,201 \times 10^{-21}$ J

Which demonstrates that the LED device of 458 nm (blue color), is much more energetic than the 656 nm (red color). By this and other motives, the LED illumination sources for indoors farming implement less devices in these type of systems.

There are 3 light growth parameters commonly used: quality, quantity and duration. All of these parameters have different effects upon the development of the plants and are presented up next (Singh; Basu; Meinhardt-Wollweber, & Bernhard, 2014).

Light quantity

Is the number of the particles named photons and also the principal parameter that affects the photosynthesis, a photo-chemical reaction inside the cells chloroplasts in which the luminous energy is used to convert the atmospheric CO₂ into carbohydrates, and from here, two variables come out, the light intensity and total daily light, commonly known as *Daily light integral (DLI)* (Singh; Basu; Meinhardt-Wollweber, & Bernhard, 2014).

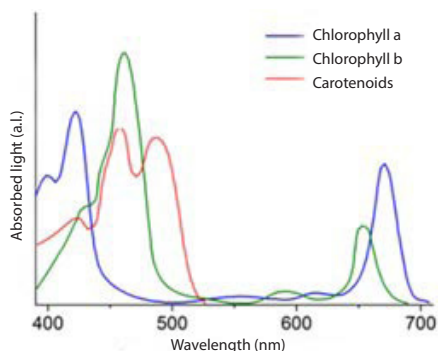

Light intensity

Is the amount of instant light that the lights receive, commonly expressed in *foot-candles, watts and lux*.

Daily light integral is the measure of the light amount received by the lights during the day in a particular area, commonly expressed by the researchers in $\mu\text{mol m}^{-2} \text{s}^{-1}$ or $\text{mol/m}^2/\text{day}$.

Light quality

It refers to the radiation spectral distribution, where casting portion is in blue, green, red and other visible and invisible wavelengths. For the photosynthesis, the plants will respond stronger to the red and blue light. The radiation spectral distribution also affects the shape, development and blooming (photo morphogenesis) (Singh; Basu; Meinhardt-Wollweber, & Bernhard, 2014).

Between 400 and 520 nm, range corresponding to the visible wavelength spectrum between the violet, blue and green light. It has strong influence upon the vegetable growth and photosynthesis.

Between 520 and 610 nm, range corresponding to the visible wavelength spectrum between the green, yellow, and orange light. It has low influence upon the vegetable growth and photosynthesis. It is through this manner that plants are green, since they reflect this light range and are is absorbed

Between 610 and 720 nm, range corresponding to the visible wavelength spectrum between the red light. It has strong influence upon the vegetable growth, photosynthesis, blooming and germination.

On Figure 2, is displayed the relative efficiency of the photosynthesis in different wavelengths.

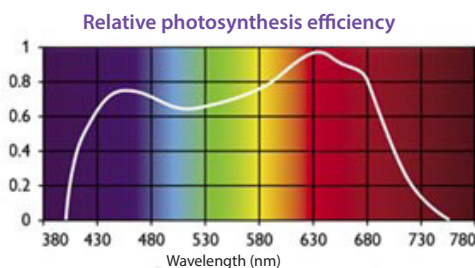

Figure 2. Effective Photosynthesis and wavelengths.
Source: MIT Technology Review.2014 & Philips Horticulture: (2014).

Light Duration

Also known as photoperiod, which mainly affects blooming. The blooming time in plants, can be controlled regulating the photoperiod, that means, the light time given to the plants.

Description of the developed system; method and operation

LP1 is an advanced electronic system, designed for indoor farming which integrates a led illumination along with control programs capable of generating appropriate conditions for the growing and development of plants in a solar light free environment. The aforementioned provides in a dynamic way the right light quality, amount and duration as the right control actions for an efficient and effective farming, allowing to save energy in comparison to other control techniques and traditional lighting sources. The Figure 3 represents a graphic description of the developed system.

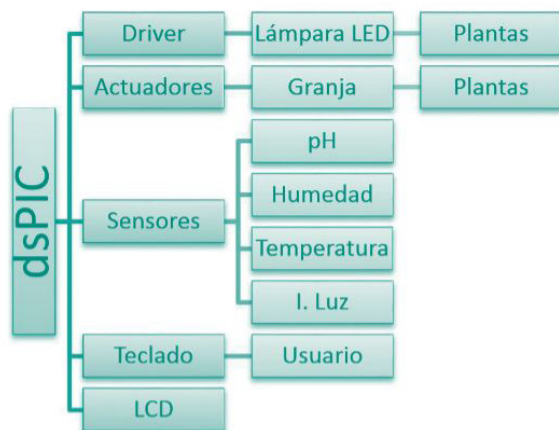

Figure 3. Graphical description of the system.

Microcontrolled or computerized systems can be used to control the environment, that is to say, a system where the temperature, humidity, light intensity and pH levels in the nutrient solutions intervene, coming in as the most relevant variables in a vertical farm for the photosynthesis process and plant growth. In order to improve the development of a specific crop and decrease the production cost it has become more important for the researchers and farmers the development of these control systems.

With the goal to provide good environmental conditions for a proper growth of plants indoors, a control

system has been developed capable of executing actions upon the mentioned variables.

The system includes:

- A sensor module ready to capture the variables that intervene in the farm.
- A FUZZY control system which benefits from the information given by the sensors in order to execute control actions and thus keeping the desirable conditions inside the farm or crop area.
- The program capable of generating the control signal for the LED illumination system.

Additionally, the control system was implemented in a dsPIC 30F4011 microcontroller as a main brain, considering the following aspects for the artificial illumination:

- Do not expose to a high light emission without resting periods to the plants, as observed in the current artificial illumination systems.
- Emulate the sinusoidal behavior of the sunlight, natural electromagnetic stimulation effect for plants and other photosynthetic organisms.
- Provide blinking or pulsating stimulation as the one exposed in the reference article.

This way and considering the previous, it is proceeded with:

Identifying of essential characteristics in an illumination system

One of the characteristics which the light source must have is the right wavelength. As mentioned earlier, the effective wavelengths for the photosynthesis process is between 400 and 500 nm and between 600 and 700 nm, wavelengths that stimulate several development stages in the plant through photo-sensitive pigmentations, as observed on Chart 1.

Chart 1. Absorption of wavelengths for photosensitive pigments.

| Wavelengths absorbed by the photosensitive pigments of the plants | | | | | | | |
|---|---------|---------|---------|---------|---------|---------|----------|
| Plant pigments | UV | Blue | Green | Yellow | Orange | Red | Deep Red |
| Wavelength (nm) | 200-400 | 400-495 | 495-570 | 570-590 | 590-620 | 620-710 | 710-850 |
| Chlorophyll A | | X | | | | X | |
| Chlorophyll B | | X | | | | X | |
| Carotenoids | | X | | | | | |
| Cryptochromes | X | X | | | | | |
| Phototropins | X | X | | | | | |
| Phytochrome red | | | | | | X | |
| Phytochrome deep red | | | | | | | X |
| All pigments | X | X | | | | X | X |

Device selection

Once identified the most effective wavelengths, a semi conductive LED devices selection stage is held. For the device selection is necessary to take in account important parameters mentioned shortly, according to its relevance,

such as: wavelength, efficiency, price and emission angle. Up next on Chart 2 are displayed some devices considered for the development of the illumination system.

Tabla 2. Dispositivos considerador para el desarrollo del sistema de iluminación

| Item (Blue LED) | Manufacturing number | Wavelength (nm) | Flux@ 25°C, test current (mW) | Price (Dollar) | Emission angle (Degrees) | Power consumption (W) |
|-----------------|--------------------------|-----------------|-------------------------------|----------------|--------------------------|-----------------------|
| 1 | XPEBRY-L1-0000-00P01 | 458 | 575 | 2,57 | 135 | 1,085 |
| 2 | XBDROY-00-0000-000000L01 | 458 | 513 | 2 | 115 | 1,085 |
| 3 | XPEBRY-L1-0000-00M01 | 458 | 538 | 2,29 | 135 | 1,085 |
| 4 | ASMT-JB31-MMP01 | 460 | 250 | 1,71 | 165 | 1,12 |
| Item (Red LED) | Manufacturing number | Wavelength (nm) | Flux@ 25°C, test current (mW) | Price (Dollar) | Emission angle (Degrees) | Power consumption (W) |
| 1 | LHCPDP-2T3T-1-0-350-R18 | 645 | 355 | 1,85 | 150 | 0,735 |
| 2 | LXZ1-PD01-0056 | 655 | 354 | 3,5 | 145 | 0,77 |
| 3 | LXML-PD01-0040 | 645 | 338 | 3,65 | 120 | 1,26 |
| 4 | LXZ1-PA01 | 655 | 350 | 2,73 | 120 | 1,125 |

Source: The Authors

Configuration of the LED matrix

Once selected the devices, the next stage consisted in the configuration or placement of such, this was designed from the fact that the blue devices are 40% more efficient than the red ones, so, the configuration and design criteria of the panel or lamp was, for every 2 red LEDs 1 blue LED, which would allow to have an almost homogeneous illumination pattern as show on Figure 4.

| ITEM | 1 | 2 | 3 | 4 | 5 |
|------|------|------|------|------|------|
| 1 | Red | Red | Red | Red | Red |
| 2 | Blue | Red | Blue | Red | Blue |
| 3 | Red | Blue | Red | Blue | Red |
| 4 | Red | Red | Blue | Red | Red |
| 5 | Blue | Red | Red | Red | Blue |
| 6 | Red | Red | Red | Red | Red |
| 7 | Red | Red | Blue | Red | Red |
| 8 | Red | Blue | Red | Blue | Red |
| 9 | Blue | Red | Blue | Red | Blue |
| 10 | Red | Red | Red | Red | Red |

Figure 4. LED panel configuration

However, at the end, the relation between the blue devices vs. red devices is of 18:32, that is to say, a 91% homogeneity pattern. Up next, on Figure 5, is shown an implemented lamp.

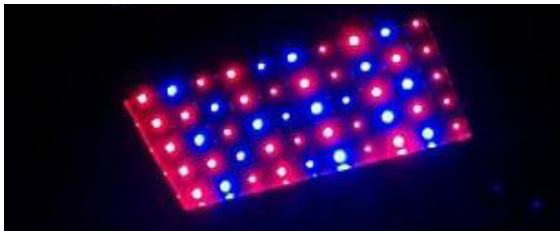

Figure 5. PCB test for the LED panel.

Electronic circuits design

Defined by the devices to be used and the lamp design, it is proceeded to design the electronic circuits which allow to emulate the solar light behavior or effect upon the plants and the casing that will store such devices. In order to feed and execute the illumination system, a feeding source capable of giving up to 105 watts required for the proper functioning of the lamp.

Later a programming code in C language was made capable of recreating through Pulse Width Modulation (PWM), the luminous intensity received by the sun in one day, thus controlling the intensity of the LED lamp for the crop illumination. In the following picture (Figure 6a and Figure 6b) it is observed the PWM signals generated from the microcontroller and captured by the oscilloscope.

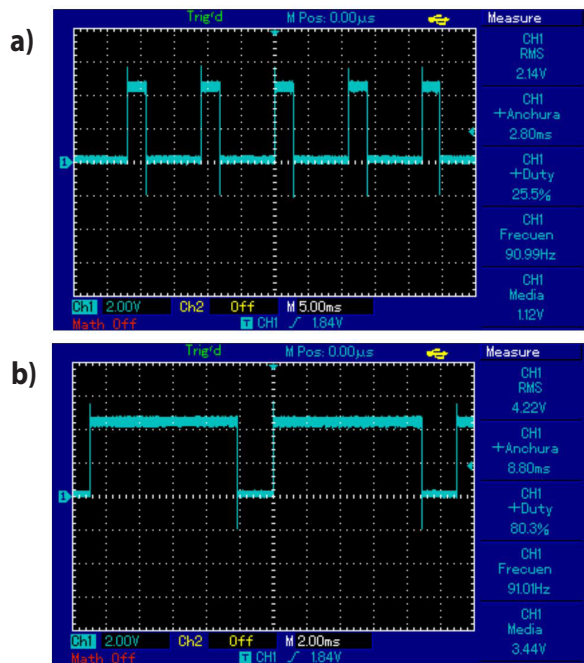

Figure 6. Generated solar signal emulation and captured by the oscilloscope, a) life cycle of 25%, b) 80%.

Results

Multiple tests allowed to corroborate that the generated signal through the microprocessor corresponds to the expected. This way, and applying the OPT101 sensor, a monolithic sensor of high response speed to small light variations, a graphic which displays the accomplishing of this objective is obtained and can be seen on Figure 7.

Up next two curves can be observed: the curve filled in red color, representing the reference or desired value and over this curve is the blue curve, the system response to the stimulation or generated PWM control signal.

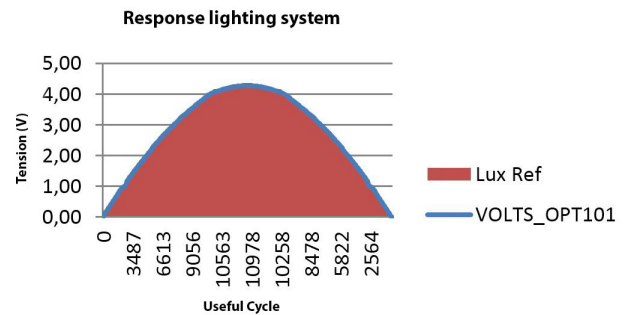

Figure 7. Response by the illumination system.

The Figure 7 indicates that the illumination system accomplishes with the expected and is capable of emulating the sinusoidal behavior of the solar light. It is worth to mention that the max tension value given by the sensor, seen in the Y axis of the graphic is proportional to the light intensity by a 100 factor. Up next, in the Figure 8, a cycle and half of the LED operation system is displayed.

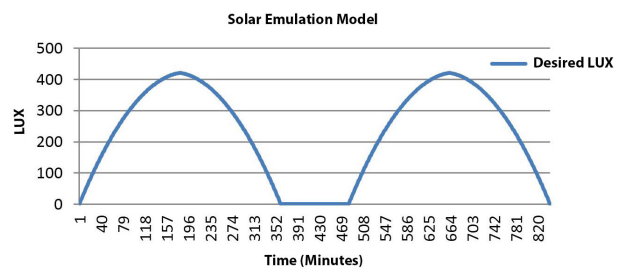

Figure 8. Solar emulation model.

The previously mention data was obtained from different tests held in the Modern Physics Laboratory in the *Universidad Autónoma de Occidente*, the programming, design and manufacturing of the electronic cards was held by the Electronics and Telecommunication Line of the *Tecnoparque SENA* node in Cali, as also the design and construction of the case for the device storage in the Line of Design and Engineering from the same technological center (See Figures 9, 10 and 11).

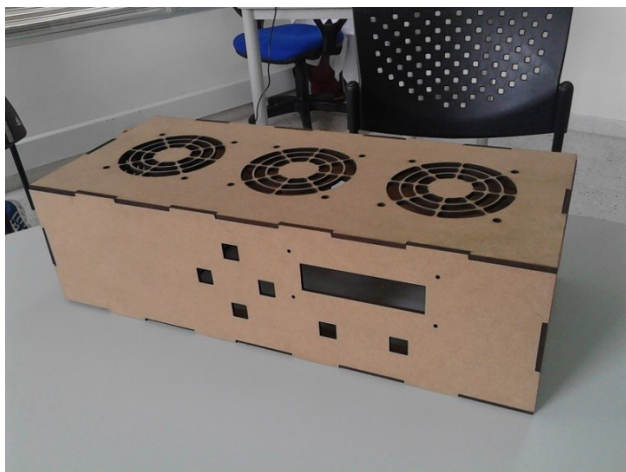

Figure 9. Case for the electronic device storage.



Figure 12. Pilot test on a vertical farm prototype

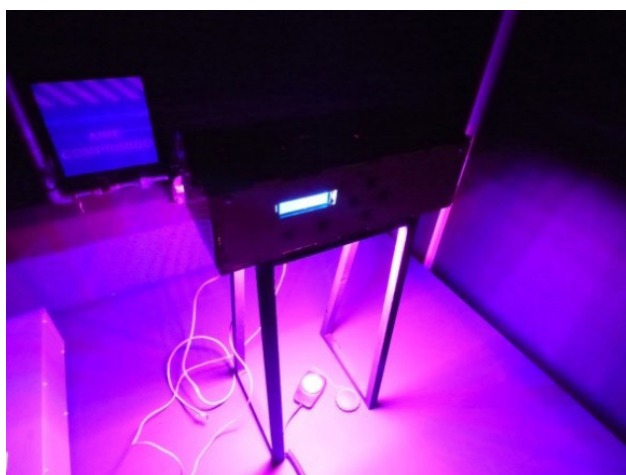

Figure 10. Function test of the LED system.

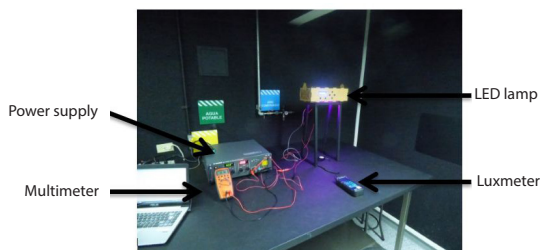

Figure 11. Luxometer recording measurement.

Once designed all the circuits and corroborated their good operation, the environmental and light control system it is put to work in a built vertical prototype farm. Which has an approximate area of 0.5 m² where 36 plants were placed over pots, net, gravel and rice husk as substrate, and a tank of 40 liters for watering and nutrient supply in the darkness periods in the illumination system. This prototype is illustrated on the Figure 12.

For fifteen days a test was held with a vertical farm obtaining promising preliminary results for a near future.

It was possible to corroborate the plants growth in a space free of natural solar radiation, that is to say, in a space where the most important variables are controlled but the natural light was replaced by the proposed and designed illumination system.

This worked without interruptions for 15 days with cycles of 6 hours of solar light effect and 2 hours for resting, this cycle is repeated 3 times a day to complete the 18 hours of artificial light and 6 of darkness. With this development it was possible to determine the importance that these 3 parameters of light growth have, since it was evidenced that a low intensity light or a short photoperiod can strongly affect the early development of the plant. This kind of issue, luckily, is easy to prove and to solve, which is why it is extremely important to make sure of the light exposition and intensity in the crops.

Conclusions

The advance of technological solid devices such as LED has allowed the progress in other areas not explored in-depth. The incursion of LED illumination for indoor farming in an overwhelming way and not as a trend but as a change for an efficient paradigm has increased. Unfortunately, the advantages in the technology, make think, according to some, that such should be used indiscriminately, looking for short-term benefits without the necessary consideration of exposed farming.

The developed systems puts in consideration the first the plants or crop health, for which the illumination system doesn't operate in a continuous way and without resting periods.

The distance of where the lamp is place may vary according to the size, and crop type and the emitted light intensity. So it is possible to place the illumination system in such way that embraces the whole farming area, approximately 30 centimeters of such, can secure a maximum luminous energy transfer for the photosynthetic process. However, it is important to point out that the placement of the light source may vary in function of the previous.

For a future work, it would be convenient to apply other electromagnetic stimulations with different photoperiods, with the goal to find a better relation.

References

- Ahmad Nizar Harun; Nurul Najwa An ; Robiah Ahmad ; Nurul Syahirah Azmi (2013) Red and Blue LED with Pulse Lighting Control Treatment for Brassica Chinensis in Indoor Farming. Recovered from <http://ieeexplore.ieee.org/xpl/login.r=6735080&url=http%3A%2F%2Fieeexplore.ieee.org%2Fxppls%2Fabstract.jsp%3Farnumber%3D6735080>
- BartaDJ,TibbitsTW,BulaRJ&Morrow,RC.Evaluation of light emitting diode characteristics for a space-based plant irradiation source. *Adv Space Res.* 1992;12:141-9.
- Caplow,T & Nelkin, J (2007). Building-integrated greenhouse systems for low energy cooling Recovered from https://scholar.google.com.co/scholar?q=Building-integrated+greenhouse+systems+for+low+energy+cooling+%5Ben+1%C3%ADnea%5D,+http://ieeexplore.ieee.org/&hl=es&as_sdt=0&as_i=scholar&sa=X&ved=0ahUKEwi66t74mL_QAhXI7SYKHxfJAKIQgQMIGDAA
- Heinrich Böll Stiftung (2009) Urban Futures 2030. Recovered from <https://www.boell.de/de/navigation/stadtentwicklung-8301.html>.
- Macías A,H; Ramos Yesid; F. Ulianov. (2012). Study of the benefits of changing high pressure sodium lamps with high brightness light emitting diodes. *The Man and The Machine* No. 39 • May-August of 2012
- MIT Technology Review.(2014). How LEDs Are Set to Revolutionize Hi-Tech Greenhouse Farming. Recovered from : <http://www.technologyreview.com/view/528356/how-leds-are-set-to-revolutionize-hi-tech-greenhouse-farming/>
- Philips Horticulture: (2014). LED solutions Recovered from http://www.lighting.philips.com/pwc_li/main/shared/assets/downloads/pdf/horticulture/leaflets/general-booklet-philips-led-lighting-in-horticulture-EU.pdf
- Singh, Devesh; Basu, Chandrajit ; Meinhardt-Wollweber,& Bernhard Roth, Merve (2014). LEDs for Energy Efficient Greenhouse Lighting. Recovered from <http://arxiv.org/ftp/arxiv/papers/1406/1406.3016.pdf>
- Specht, Kathrin; Siebert, Rosemarie; Hartmann, Ina; Freisinger, Ulf; Sawicka, Magdalena; Werner, Armin; Thomaier, Susanne; Henckel, Dietrich; Walk, Heike; Dierich, Axel. (2014). Urban agriculture of the future: an overview of sustainability aspects of food production in and on buildings. *Agriculture & Human Values.*, Vol. 31 (1) 33-51.
- Tennessen DJ, Singsaas EL & Sharkey TD.(1994). Light-emitting diodes as a light source for photosynthesis research. *Photosynth Res*, 39:85-92.

The theory behind the concept of vertical farming. South Carolina. Recovered from http://media.clemson.edu/public/restoration/iae/vfarm/student_verticalfarming.pdf.

Tongxin Shi; Yuntao Ma; Jie Wu; Xiang Li; Yan Guo; Zhaoli Xu; Yan Jin; Yuhong Yang (2012). Quantification of Light Absorption and Photosynthesis of Tobacco Canopy Using 3-D Modeling. Recovered from http://ieeexplore.ieee.org/xpl/login.r=6524855&url=http%3A%2F%2Fieeexplore.ieee.org%2Fxp1s%2Fabs_all.jsp%3Farnumber%3D6524855

Winter Green Research. (2014). Plant Factory / Vertical Farming Market Shares, Strategies, and Forecasts, Worldwide, 2014-2020. Recovered from <https://www.reportbuyer.com/product/2107872/plant-factory-vertical-farming-market-shares-strategies-and-forecasts-worldwide-2014-2020.html>

Yeh N & Chung JP. (2009). High-brightness LEDs – energy efficient lighting sources and their potential in indoor plant cultivation. *Renew Sust Energ Rev.* 13:2175–2180.